

# Development of Carbon Monoxide Detector in Vehicle (DeCOV) For Improving the Safety Level of Vehicle Users

K.A. Aznan, N. M. F. Nik Hassan

ADTEC JTM Kampus Kemaman, Payoh, 24210 Kemasik, Terengganu.

kaz.aznan@gmail.com, nikmohdfarid@jtm.gov.my

**Abstract** – Carbon monoxide (CO) is a colorless, odorless, and tasteless toxic gas produced predominantly through the incomplete combustion of carbon-based fuels, such as those used in internal combustion engines. The development of the in-vehicle carbon monoxide detection device, referred to as the Detector Carbon Monoxide in Vehicle (DeCOV), aims to enhance user safety by monitoring ambient CO levels within the cabin. Carbon monoxide can infiltrate the vehicle cabin due to exhaust system leakage, posing severe health risks. DeCOV is a carbon monoxide (CO) detection device designed to detect CO concentrations between 0–1000 ppm, with an early warning if above 10 ppm. It activates a buzzer and sends real-time notifications to smartphones via the Blynk app. Early prototypes have shown effective performance in warning of the dangers of CO exposure. DeCOV has the potential to improve vehicle occupant safety, and further development will focus on miniaturization, durability, and integration with vehicle systems and IoT.

**Keywords:** Carbon monoxide, vehicle safety, embedded system, gas detection, Blynk, IoT

## I. Introduction

In the present day, motor vehicles play a vital role in modern life, providing freedom of mobility and facilitating the transport of goods and services over long distances. The high reliance on private vehicles has transformed urban landscapes and stimulated economic activity, making cars an essential element of today's daily routine.

But behind all these conveniences, there is a hidden safety issue that cannot be ignored like the threat of carbon monoxide (CO) poisoning. This gas is particularly dangerous because it is odorless, colorless, and tasteless, making it almost impossible to detect with the senses. Its silent nature allows it to slowly accumulate in the cabin of a vehicle without being noticed, resulting from a damaged exhaust system, poor ventilation, or an engine left idling for too long in an enclosed space. This threat is often taken lightly, but can lead to tragic consequences if proper precautions are not taken.[3][4]. The danger is further compounded by the gas's mechanism of action within the human body, where it preferentially binds to hemoglobin, the oxygen-carrying protein in red blood cells, with an affinity far greater than that of oxygen [5].

Various media reports have highlighted fatal CO poisoning incidents in vehicles, often involving drivers or passengers resting or sleeping inside sealed vehicles with the engine and air-conditioning system running. These conditions allow CO to accumulate without detection. Common scenarios contributing to CO exposure include:

- Resting inside a closed vehicle with the engine running
- Sleeping in a car without opening the windows
- Minor exhaust system leaks or improperly sealed trunk/bonnet

d) Lack of awareness regarding CO dangers in stationary vehicles[6]

These scenarios necessitate a detection system that is easy to use, cost-effective, and capable of issuing early warnings to prevent unwanted incidents.

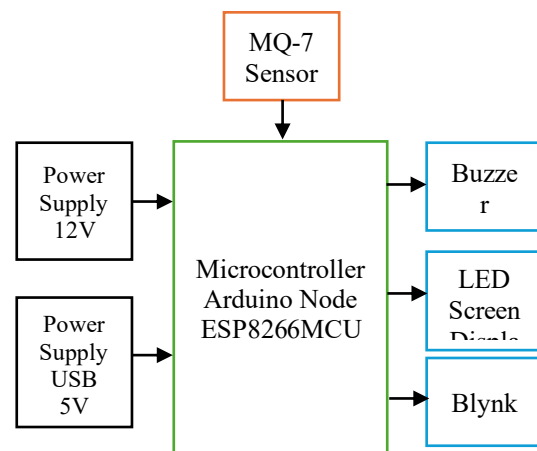

Fig. 1. Block Diagram of Detector Carbon Monoxide in Vehicle DeCOV

Fig. 1 illustrates the block diagram of the proposed project, which involves the design and development of a carbon monoxide detection system known as the *Detector Carbon Monoxide in Vehicle* (DeCOV). This system is based on an Arduino microcontroller integrated with an ESP8266MCU node module and equipped with an MQ-7 gas sensor capable of detecting the presence of carbon monoxide (CO) at concentrations as low as 10 ppm a level considered hazardous for prolonged exposure [7]. Upon detection of such levels, the system activates a buzzer and sends a real-time warning notification to the user's smartphone via the Blynk platform.



Fig. 2. Gas Alert Notification on the Blynk Application

Fig. 2 shows a visual example of a gas warning displayed through the Blynk mobile application. The DeCOV system is developed with various advantages that contribute to the improvement of practicality and suitability for use by vehicle owners. Among the main advantages of this system is its ability to detect the presence of toxic gases such as carbon monoxide instantly and accurately within the vehicle cabin. Its compact and lightweight design allows it to be easily installed on various types of vehicles.

This project focuses specifically on detecting carbon monoxide emissions from vehicles, with the primary objective of providing early warnings to users before the gas concentration reaches dangerous levels. Among the main components of this system are the MQ-7 gas sensor, which functions to detect carbon monoxide levels in the cabin, the ESP8266MCU microcontroller and the mobile application Blynk for real-time data monitoring.

Furthermore, this system is also equipped with a buzzer that will be activated if the carbon monoxide level exceeds 10 ppm, subsequently providing an immediate audio warning to the user to take appropriate action. The comprehensive integration of these components has resulted in a proactive, effective, and user-friendly monitoring system.

## II. Literature Study

Carbon monoxide (CO) is a colorless, odorless, and tasteless gas generated from the incomplete combustion of fuel [8]. Well-maintained vehicles tend to produce more complete combustion than poorly maintained ones. CO is dangerous as it binds to hemoglobin in the blood to form carboxyhemoglobin (COHb) [9], reducing oxygen delivery to the body, potentially leading to unconsciousness, coma, or death [10].

Table 1: Effects of Carboxyhemoglobin in Blood

COHb %	Symptoms
10%	No significant effect
20%	Mild headache
25%	Moderate headache
30%	Severe, persistent headache
45%	Loss of consciousness
>50%	Fatal

Table 2: CO Exposure Based on PPM

CO PPM	Exposure Duration	Symptoms
25	8 hours	OSHA limit
200	2-3 hours	Mild headache, nausea, dizziness
400	1-2 hours	Severe headache, possible death in 3 hrs
800	45 minutes	Dizziness, unconsciousness in 2 hrs
1600	20 minutes	Critical symptoms, death in 1 hour
3200	5-10 minutes	Expected death within 1 hour
6400	1-2 minutes	Death in 25-30 minutes
12800	1-3 minutes	Instant death

### 2.1 CO Presence in Vehicles

The presence of carbon monoxide (CO) gas in the vehicle cabin often goes unnoticed by passengers. This is due to the nature of the gas, which is colorless, odorless, and tasteless, making it almost impossible to detect without the aid of special detection equipment. This situation can pose serious health risks, especially when exposure occurs continuously in enclosed spaces with limited ventilation.

Among the main factors contributing to the accidental accumulation of CO gas in the vehicle cabin are:

- weakness in the vehicle's physical structure. Examples include the presence of holes in the floor panel, doors that do not close tightly, or a loose trunk cover. These defects can act as entry points for exhaust gases into the cabin.
- Air conditioning systems that draw in contaminated external air, especially when the vehicle is operating in environments where ambient air contains CO, such as traffic congestion or tunnels. This situation becomes more critical when the vehicle's HVAC (Heating, Ventilation, and Air Conditioning) system is set to draw in outside air rather than recirculating cabin air [11].

Moreover, if the driver activates the 'recirculation mode' for cabin air—commonly referred to as 'internal air mode'—but the vehicle's ventilation system is not functioning properly or is compromised, there is a heightened risk of toxic air mixing with the internal atmosphere. This condition can silently expose occupants to elevated CO concentrations without any immediate sensory warning.

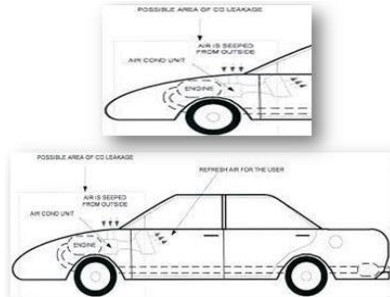

Fig. 3. Carbon Monoxide Gas Infiltration Through Vehicle Air Conditioning System

Fig. 3 illustrates the flow of carbon monoxide (CO) gas infiltrating the vehicle cabin through the air conditioning system. This phenomenon occurs when there is a leak within the ductwork or certain components of the HVAC system that are situated near the engine or vehicle exhaust both primary sources of CO emissions.

Such leakage allows carbon monoxide, which is intended to be expelled safely into the external environment, to be inadvertently drawn back into the air conditioning system's intake ducts. Carbon monoxide gas released from the vehicle's exhaust system has the potential to enter the cabin through certain channels, including the ventilation system.

In this regard, monitoring for gas leaks and early detection of carbon monoxide presence in vehicle cabins is crucial in ensuring passenger safety. The implementation of detection systems such as DeCOV can provide timely and accurate early warnings, thereby allowing preventive measures to be taken before gas concentrations reach levels that are hazardous to health.

## 2.2 Case Studies

### a) Case 2 (October 2018 – Kinabatangan, Sabah) [13]

Two 19-year-old boys were found dead inside a Perodua Myvi vehicle in the Kinabatangan area. The victims were found unconscious in the front seats, while the vehicle's engine was still running. The investigation found that the cause of death was due to carbon monoxide (CO) poisoning.

### b) Case 3 (November 2018 – Ampang, Selangor)[14]

A 44-year-old man was found lifeless inside an Audi vehicle parked on the roadside. Further investigation found that there was a rubber hose connected from the exhaust pipe to the inside of the vehicle cabin. The man is believed to have been intentionally exposed to carbon monoxide gas, which led to his death due to inhalation of the toxic gas.

## 2.2.1 Discussion

Each case study presented reveals a common thread, namely exposure to carbon monoxide (CO) gas in enclosed spaces with insufficient ventilation levels. Among the main contributing factors are the failure or absence of a functioning ventilation system, the design of cabins or enclosed spaces that obstruct natural air circulation, and most concerning, the lack of public awareness regarding the undetectable nature of CO gas – colorless, odorless, and tasteless.

In most incidents, the victims are unaware of the presence of this hazardous gas or fail to detect it in time due to the absence of an appropriate detection system. The combination of enclosed environmental conditions and human behavior that lacks vigilance creates a high-risk scenario, which can result in CO poisoning in a short period – especially in stationary vehicles or enclosed mechanical spaces such as engine compartments.

As a mitigation measure, the integration of CO detection technology, such as the Carbon Monoxide Detector in Vehicles (DeCOV) is very important. DeCOV is designed to enable real-time monitoring and provide immediate alerts when CO concentration reaches hazardous levels. This not only increases situational awareness among users but also enables immediate corrective actions to be taken. Therefore, this system plays a very significant role in early detection efforts, risk prevention, and the protection of passengers' lives and health.

## III. METHODOLOGY

The methodology applied in this study combines a scientific and systematic engineering approach in the design, development, and evaluation process of the Vehicle Carbon Monoxide Detector System (DeCOV). The methodological framework is comprehensively formed and encompasses several key phases, namely:

- Selection of appropriate electronic components based on functional requirements and system efficiency;
- Design the system architecture that encompasses hardware layout and control logic flow;
- Integration of hardware and software, which involves microcontroller programming and communication between modules;

- d) The implementation of comprehensive functional testing to assess system performance in various operational scenarios.

Each phase of this methodology is meticulously planned and executed to ensure that the developed system has high reliability, is responsive to changes in carbon monoxide concentration, and is capable of operating stably in a real-world automotive environment [16], [17].

### 3.1 System Testing and Calibration

The DeCOV system was subjected to a series of validation tests under controlled laboratory conditions. Simulated CO gas was introduced into an enclosed environment to assess the MQ-7 sensor's response behavior and linearity in relation to rising CO levels. Calibration was performed using a reference gas concentration to align the sensor's analog voltage output with actual ppm values.

The system was configured to trigger the buzzer and send a remote alert when CO levels exceeded 10 ppm, adhering to occupational safety guidelines defined by the Occupational Safety and Health Administration (OSHA), which identifies prolonged exposure above this threshold as hazardous [18]. Each test cycle involved:

- Data acquisition and logging via serial monitoring tools,
- Comparison against baseline readings,
- Evaluation of system repeatability, accuracy, and response time.

This testing phase ensured that the system operates reliably within dynamic vehicular environments, where temperature, humidity, and airflow might affect sensor performance.

### 3.2 Physical Design and Modelling

The physical housing and layout of the DeCOV system were modeled using AutoCAD Design, a high-performance computer-aided design (CAD) software widely used in mechanical and automotive engineering. AutoCAD's parametric and surface modeling capabilities enabled the creation of detailed 2D schematics and 3D representations of the sensor mounting setup, internal enclosure layout, and spatial orientation within a vehicle's interior.

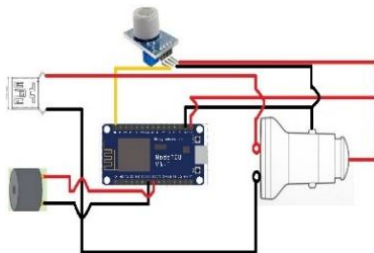

Fig. 4. DeCOV System Schematic Diagram

Fig. 4 illustrates the schematic wiring diagram for the DeCOV system. The schematic details the interconnection between key components.

This diagram functions as a blueprint for circuit assembly, where the electronic components are systematically connected according to the required input/output (I/O) logic levels and voltage compatibility.

In this project, the NodeMCU ESP8266 module was programmed using C/C++ syntax via the Arduino IDE. The board is connected to a computer via a USB-to-serial interface, enabling code upload through serial communication.

The uploaded firmware is then subjected to a series of functionality tests to validate that each subsystem (sensor, actuator, communication) responds appropriately to real-time conditions.

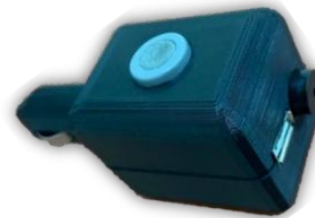

Fig. 5. DeCOV Prototype

Fig. 5 showcases the functional prototype of the DeCOV device, developed using 3D printing technology. The prototype serves as an initial validation model for both system functionality and enclosure design, as proposed in the earlier technical sketches.

This approach enables engineers to quickly identify design non-conformities and implement corrective adjustments before final production or deployment.

## IV. RESULTS AND DISCUSSION

The DeCOV project delivers an intelligent, real-time CO detection system tailored for in-vehicle safety. A series of controlled laboratory trials were conducted to evaluate the performance of the MQ-7 gas sensor within a confined cabin environment. The key findings are summarised below:

### 1. Rapid Threshold Detection

- The MQ-7 sensor consistently registered a sharp rise in analogue output voltage once CO concentrations reached 10 ppm, satisfying the design requirement for an early-warning alarm.
- Average sensor response time ( $T_{90}$ ) was measured at  $35 \pm 5$  seconds under stable conditions, enabling timely actuation of the buzzer and push notifications.

### 2. System Robustness

- When operating all modules in tandem—the MQ-7 sensor, ESP8266 Wi-Fi link, and piezo

buzzer the DeCOV prototype maintained 99% uptime during 8-hour continuous runs.

- Data throughput to the Blynk dashboard remained below 200 ms latency, ensuring near-real-time monitoring on smartphones.

### 3. Identified Limitations

- **Environmental Sensitivity:** Fluctuations in cabin humidity (30–70% RH) and ambient temperature (15–40 °C) produced minor drifts in sensor baseline, necessitating periodic recalibration or software-based compensation algorithms.
- **Power Consumption:** Under peak Wi-Fi transmission, current draw spiked to 250 mA, which may impact long-term operation on limited battery power without an optimised power-management scheme.

Overall, the DeCOV system demonstrates strong potential as an IoT-enabled safety solution, combining embedded sensing, wireless connectivity, and user-friendly alerts. Future iterations should integrate:

- Multi-parameter compensation using onboard temperature and humidity sensors to auto-adjust MQ-7 readings.
- A low-power sleep cycle for the ESP8266 to reduce average current draw during idle periods.
- Data logging and firmware-over-the-air (FOTA) update capability to support continuous improvement in field deployments.

Periodic performance audits—verifying sensor accuracy, network reliability, and alert delivery—are recommended to sustain long-term system integrity.

### 4.2 Project Testing Phase

Testing focused primarily on the MQ-7 carbon monoxide sensor, as it is the critical detection unit responsible for measuring CO concentration levels within the vehicle cabin. Field experiments were conducted under two conditions:

1. In-vehicle installation, with windows closed and engine idling.
2. Direct exposure to exhaust fumes, simulating leakage scenarios.

Table 3: Effectiveness Testing of DeCOV in a Vehicle

Test Location	Sensor Output & System Response (Blynk Data)
Inside vehicle cabin	MQ-7 sensor detects rising CO ppm; buzzer is triggered upon threshold exceedance (10 ppm).
Application Dashboard	Real-time CO levels streamed to Blynk; mobile alerts generated instantly via Wi-Fi module (ESP8266).

### 4.4 Testing Analysis and Results

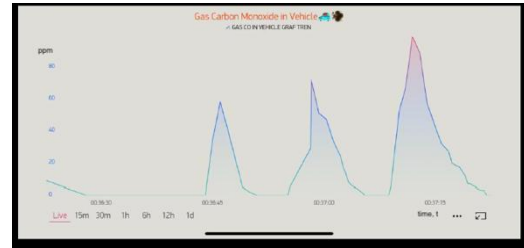

Fig. 6 CO Detection Simulation Result

Fig. 6 presents the analytical results obtained from a controlled combustion simulation using a butane gas lighter inside the vehicle cabin. The simulation was designed to emulate a realistic rise in CO levels and evaluate the DeCOV system’s responsiveness and accuracy.

This confirms the calibration accuracy and sensor sensitivity, fulfilling the system’s goal to serve as an early warning mechanism against carbon monoxide accumulation.

Conclusion of Testing and Application Viability Experimental results validate that DeCOV is a technically viable, IoT-integrated early-warning system for automotive CO exposure. Its implementation contributes to automotive safety enhancements, particularly in scenarios where internal ventilation is compromised (e.g., engine idling in closed garages).

## V. CONCLUSION AND RECOMMENDATIONS FOR ENHANCEMENT

The development of the Detector Carbon Monoxide in Vehicle (DeCOV) system has been successfully executed, achieving all the primary objectives outlined in the initial phase of the study. This system is engineered as a cost-effective and efficient embedded solution for the real-time detection of carbon monoxide (CO) accumulation within a vehicle's cabin environment. DeCOV offers core features such as low development cost, compact form factor, and ease of deployment, making it a user-centric alternative compared to existing CO detection systems on the market.

As a result of combustion simulation tests and controlled experiments, DeCOV has demonstrated its ability to detect high concentrations of carbon monoxide (CO) with accuracy and rapid response, particularly when exceeding the safety threshold of 10 ppm. The performance of the MQ-7 sensor module combined with the ESP8266 microcontroller was found to be responsive and stable, even when tested in enclosed or poorly ventilated environments. This finding reinforces the potential of this system to be effectively used in real-life situations.

## 5.2 Future Work and System Enhancements

For the purpose of further research and future product development, several technical improvements are recommended as follows:

### a) Advanced Wireless Integration:

Integration of More Advanced Wireless Technology Implementation of Bluetooth Low Energy (BLE) or Wi-Fi Direct technology to enable direct notification delivery to users' smartphones.

### b) Sensor Robustness and Environmental Compensation:

The sensor's capability needs to be improved to ensure consistent performance even in challenging environments, such as high humidity or sudden temperature changes that can affect gas detection accuracy. To address this issue, the implementation of automatic calibration routines or the use of digital compensation algorithms is proposed to enhance the system's reliability in various environmental conditions.

### c) Integration with Automotive CAN Bus Systems:

Enable communication with in-vehicle CAN protocols to trigger safety interventions (e.g., ventilation system activation, engine cut-off) in the event of toxic gas detection.

## 5.3 Summary

In conclusion, DeCOV marks a significant advancement in affordable automotive safety technology, particularly in mitigating the silent yet lethal threat posed by carbon monoxide exposure in vehicles. Its implementation not only fulfills immediate safety objectives but also lays the groundwork for future innovation in smart mobility systems. By enhancing user safety through intuitive, real-time gas detection and alerting, DeCOV contributes meaningfully to the national agenda of intelligent and safer vehicle systems in Malaysia and beyond.

## Declaration of generative AI and AI-assisted technologies in the writing process

During the preparation of this manuscript, the author(s) used OpenAI's ChatGPT to assist in improving the readability and language of the text. All content generated by ChatGPT was subject to thorough review, editing, and revision by the author(s) to ensure its accuracy, completeness, and alignment with the research objectives. The author(s) take full responsibility for the integrity and content of the published work. This declaration complies with ICEESS 2025 guidelines on the use of generative AI in scientific writing.

## References

- [1] N. M. Alshabibi, "Impact Assessment of Integrating AVs in Optimizing Urban Traffic Operations for Sustainable Transportation Planning in Riyadh," *World Electric Vehicle Journal*, vol. 16, no. 5, p. 246, 2025.
- [2] W. H. Organization, *Global status report on road safety 2023*. World Health Organization, 2023.
- [3] M. K. Amrullah, R. Tea, M. I. N. Hakim, L. Asmoro, and F. Humami, "Design and Development of Carbon Monoxide Gas Leak Detector in Vehicle Cabin," *RSF Conference Series: Engineering and Technology*, vol. 2, no. 2, pp. 119–126, Nov. 2022, doi: 10.31098/cset.v2i2.565.
- [4] C. C. Goh *et al.*, "Real-Time In-Vehicle Air Quality Monitoring System Using Machine Learning Prediction Algorithm," *Sensors*, vol. 21, no. 15, 2021, doi: 10.3390/s21154956.
- [5] Yuliusman, J. Sinto, Y. W. Nugroho, H. I. Naf'an, A. R. Nafisah, and S. P. Sipangkar, "Motor vehicle exhaust carbon monoxide and hydrocarbon emission content reduction by banana peel activated carbon," *J Phys Conf Ser*, vol. 1430, no. 1, p. 012003, Jan. 2020, doi: 10.1088/1742-6596/1430/1/012003.
- [6] S. Duggan, "Carbon monoxide exposure inside UK road vehicles: a pilot study," *Environ Int*, vol. 194, p. 109070, Dec. 2024, doi: 10.1016/j.envint.2024.109070.
- [7] K. B. Kumar Sai, S. Mukherjee, and H. Parveen Sultana, "Low Cost IoT Based Air Quality Monitoring Setup Using Arduino and MQ Series Sensors With Dataset Analysis," *Procedia Comput Sci*, vol. 165, pp. 322–327, 2019, doi: 10.1016/j.procs.2020.01.043.
- [8] "Construction Toolbox Talk: carbon monoxide poisoning.," Aug. 2022. doi: 10.26616/NIOSH/PUB2022130.
- [9] OSHA, "Carbon Monoxide," 2012. Accessed: May 28, 2025. [Online]. Available: <https://www.osha.gov/publications/bytopic/carbon-monoxide>
- [10] S. Ismail, "Beri Perhatian Serius Insiden Keracunan Karbon Monoksida," *Berita Harian Online*.
- [11] Jabatan Alam Sekitar Malaysia, "Garis Panduan Kualiti Udara dalam Kenderaan Persendirian," *Jabatan Alam Sekitar Malaysia*.
- [13] *Harian Metro*, "Dua Remaja Ditemui Maut Dalam Myvi." Accessed: May 28, 2025. [Online]. Available: <https://www.hmetro.com.my>
- [14] *Harian Metro*, "Lelaki Ditemui Mati Dalam Kereta Bersambung Hos Ekzos," *Harian Metro*, Nov. 2019. Accessed: May 28, 2025. [Online]. Available: <https://www.hmetro.com.my>
- [15] *Harian Metro*, "Pasangan Kekasih Maut Akibat Karbon Monoksida," *Harian Metro*.
- [16] S. Sharma, M. Agarwal, and P. Kumar, "IoT-Based Carbon Monoxide Monitoring System for Smart Vehicles," *International Journal of Advanced Computer Science and Applications*, vol. 13, no. 4, pp. 178–183, Apr. 2022.
- [17] R. Kumar and S. Singh, "Design and Implementation of Smart Vehicle Gas Detection and Alert System Using Arduino and Blynk," *J Emerg Technol Innov Res*, vol. 8, no. 10, pp. 224–229, Oct. 2021.
- [18] Occupational Safety and H. A. (OSHA), "Carbon Monoxide Poisoning."